

Системы телекоммуникации, связи и защиты информации

UDC 621.396.946.2

Al-Shuraifi Mushtaq¹, Mikhail Reznikov¹, Ph.D., Al-Zayadi Haider²¹ Taras Shevchenko National University of Kyiv,Radio Physics Faculty, Department of Radio Engineering and Radio electronic systems,
64/13, Volodymyrska Street, City of Kyiv, Ukraine, 01601,e-mail: Mushtaq_talib2005@yahoo.com, e-mail: mir@univ.kiev.ua.² Lviv Polytechnic National University,

Institute of Telecommunications, Radio Electronics and Electronic Technics

2, profesors' ka str., l'viv, 79013, Ukraine, e-mail: hydertop@yahoo.com

How to improve Bit Error Rate and throughput by Resource Management and affect it on Quality of Service and Modulation and Coding Schemes in Resource Block for LTE

New cross-layer scheduling algorithm to satisfy better Quality of Service (QoS) parameters for real time applications has been proposed in this paper. The proposed algorithm builds on allocating resource blocks (RB) with different modulation and coding schemes (MCS) according to bit error rate (BER). The authors admit that nowadays great attention is paid to Radio resource management algorithms development. Such algorithms improve radio resources application, making the enhanced throughout telecommunication system available to users. Radio resources management includes transmission power management, mobility management, radio resources scheduling etc. Smart radio resource management is the major task of LTE, which enables LTE to become a reliable technology, meeting the broadband mobility requirements in upcoming years. The given algorithm will schedule the available resources to the best advantage and afford users enough data transmission opportunity, even while they freely move. Moreover, the assigned resources QoS would not interfere with already assigned resources. References 8, figures 4.

Keywords: Long Term Evaluation (LTE), Resource Block (RB), Quality of Service (QoS), Modulation and Coding Schemes (MCS), resources management, Transmission Time Interval (TTI), Channel Quality Indicator (CQI), base station (BS), Physical Resource Blocks (PRB).

Introduction

Long Term Evolution (LTE) is the name given to a 3GPP project to evolve UTRAN to meet the

needs of future broadband cellular communications. This project can also be considered as a milestone towards 4G standardization. Different organizations and individuals are involved in this project to specify requirements of LTE which satisfies both operators and consumers. With OFDM as its key technology, 3G LTE (Long Term Evolution) has improved and enhanced 3G air interface technology hence outperforms traditional 3G system. Dynamic resource allocation is a crucial measure to improve spectrum efficiency and to ensure QoS requirement in 3G LTE system. In radio environment, one Resource Block (RB) which suffers from deep fading on one user may be in an excellent condition for other users. Therefore, the scheduler in the base station (BS) may assign the RB to a favorable user to achieve high resource exploitation rate and system throughput. LTE has a frame duration of $T_f = 10$ ms and it is divided into equally size sub-frame, called Transmission Time Interval (TTI), lasting 1 ms. The whole bandwidth is divided into 180 kHz physical RBs, each one lasting 0.5 ms and consisting of 6 or 7 symbols in the time domain (according to the OFDM prefix-code duration) as shown in figure 1[1].

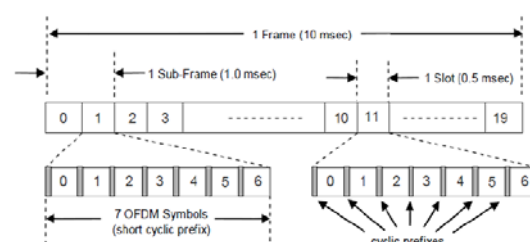

Figure 1. LTE Frame structure

Every TTI, the Channel Quality Indicator (CQI) is reported by the user measurement entity to the base station (BS) to provide time and frequency channel quality information for better spectral efficiency and resource allocation. For downlink RBs, users use the Physical Uplink Control Channel (PUCCH) to convey channel quality information to the BS. BS conveys downlink RBs allocations and MCS assignments to all users using the Physical Downlink Control Channel (PDCCH) [1]. User-level QoS allocation problem could be divided into allocating RBs and power to individual users under various constraints. Since, the joint optimization problem of allocating RBs and power optimally to satisfy user-level QoS under the total available power constraint, involves discrete assignment and is thus not convex in the unknowns of RBs allocation and the available power, making it a Non-deterministic Polynomial (NP)-hard problem [2].

2. SYSTEM MODEL

The LTE transmitter and receiver with cross-layer design as shown in figure (2) below which allocate RBs in a frame to different users. Frequency Division Duplex (FDD) is assumed to be the operation mode.

We can see in each symbol have many of sub-carrier and All RBs in the set are available for allocation to users. Following the LTE standard constraints in [3, 4], all RBs have the same grid size, subcarriers in each RB have the same MCS, and all RBs allocated to a user in one TTI have also the same MCS

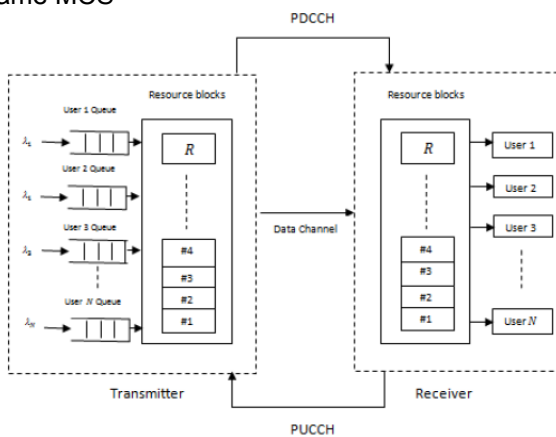

Figure 2. LTE model for cross-layer design and RB allocation

From figure above it can see At the transmitter, there are number of users each of them is represented as M/D/1 queue [6]. Data packets arrive at queue n according to Poisson process with arrival rate λ_A bits per frame.

All OFDM symbols in a TTI have the same transmit power due to the fact that each RB has the same MCS and thus the same number of allocated bits to each of its subcarrier. Each TTI can have different transmit power. The conclusion from this model that allocates RBs and assigns MCS to each RB, is to minimize the overall average packet delay for all users specially who has real time traffic while providing the BER requirement, queue stability constraint, power resource limitation, channel condition awareness, supportable MCS, and transport block constrains [7]. It will be better to enter more deep in radio resource scheduling and take one or two algorithm before take more detail how to affect QOS and MCS on resource block.

2.1 Radio Resource Scheduling

Radio resource scheduling is a process in which resource blocks are distributed among the UEs. Before the eNodeB can assign the modulation technique and coding rate to an UE, based on the transmission channel condition, it must be assigned radio resource blocks. The details of RRB are given in section 2.2.1.

Due to the rapidly and instantaneously changing nature of radio channel quality there must be a fast enough scheduling algorithm to compensate the changing channel conditions. Radio resources are scheduled every 1ms in 3GPP LTE and different frequency bandwidths i.e. 1.25, 2.5, 5, 10, 15, 20 MHz or an aggregated bandwidth can be assigned to an individual user based on the channel condition and availability. Thus, the task of the scheduling in 3GPP LTE i.e. RRBs distribution among users, is more complex.

2.2 Resources Scheduling Algorithms

A number of the radio resource scheduling algorithms have been proposed in the literature and are described briefly in the following subsections.

2.2.1 Proportional Fairness Resource Allocation Scheme Algorithm

In Proportional Fair (PF) scheduling algorithm for OFDMA [8], the priority for each user at each resource block is calculated firstly and then the user with maximum priority is assigned the RB and the algorithm continues to assign the RB to the user with next maximum priority. This process continues until all RBs are assigned or all users have been served with RBs. The priority of k^{th} user for j^{th} resource block in time 'n' is calculated as follows.

$$P_{k,j}(n) = RDR_{K,J}(n) / R_k(n) \quad (1)$$

Here $RDR_{K,J}(n)$ denotes the requested data rate for the k-th user over the j-th RB in time n and $R_k(n)$ is the low-pass filtered averaged data rate of the k-th user. RDR is estimated using AMC (Adaptive Modulation and Coding) selection which is based on current transmission channel condition. RDR for retransmissions is clearly separated from the RDR of new resource requests as retransmissions must be treated specially to guaranty their successful reception at the receiver and in that case RDR is estimated as follows

$$RDR_{K,J}(n) = R_{MCS}(SNR_{AC}) \quad (2)$$

Here RMCS is the rate estimation function and SNRAC is the accumulated signal to noise ratio over the transmission channel. On each interval of scheduling, the $R_k(n)$ is updated as follows

$$R_k(n+1) = (1-a)R_k(n) + a \cdot RDR_k(n) \quad (3)$$

where 'a' is average rate window size and $RDR_k(n)$ is the aggregate data rate of user k time n.

2.2.2 Softer Frequency Reuse based Resource Scheduling Algorithm

In order to reduce the frequency selective scheduling gain loss and to increase the data rate at cell edge, the softer frequency reuse scheme is proposed. In this scheme the frequency reuse factor both at cell center and cell edge is 1. The high power frequency band is different between neighboring cells.

The designed frequency scheduler runs in a way that the cell edge users have the greater probability to use the frequency band with higher power and the cell center users have the higher probability of using frequency band with lower power. We need to do a little modification in PF scheduling algorithm as follows

$$P_{k,j}(n) = \frac{RDR_{K,J}(n)}{R_k(n)F_{k,j}} \quad (4)$$

where $F_{k,j}$ is the priority factor and can be one of the following

- $F_{1,1}$, User k at cell center, RB j is low power
- $F_{1,2}$, User k at cell center, RB j is high power
- $F_{2,1}$, User k at cell edge, RB j is low power
- $F_{2,2}$, User k at cell edge, RB j is high power
- $F_{k,j}$ can have the value between 0 and 1.

Here we can easily assign the values to $F_{k,j}$ to control the resource assignment to users at cell center and cell-edge.

2.2.3 Resource Scheduling Algorithm based on Dynamic Allocation

This scheme performs efficient radio resource utilization in different types of network traffic. Conversational class traffic is transmitted on the network in small chunks which

are considerably smaller than the packets of streaming class traffic. In this algorithm the equal allocation of the radio resources is ensured but not the

capacity of traffic that they can handle with these physical resource blocks (PRB). This algorithm is outlined below

Initialization

N=50 (1, 2..., 50)

Until N=0

Foreach k in U

RB->k; the user k selects best PRB from N depending on channel condition

N = N - RB

End Foreach

End Until

Where

N = Total number of available physical resource blocks

U = Total users to multiplex on a physical resource block

RB = Resource block which are assigned to k user

3. QOS BASED ALGORITHM

The proposed algorithm has two phases, the first phase is the RB allocation phase while the second one is the MCS assignment phase.

In this algorithm the sub-carrier controller combines the CQI and the QoS information which is transferred from the traffic controller in the MAC layer to distribute the resources among the users with taking into account.

The available resource blocks are allocated to users through an iterative process, where the total number of iterations is equal to the total number of RBs available at each frame. At each iteration only one RB is allocated to the user which maximizes the following proposed priority function

$$PRF(n) = \frac{T_w(n) \cdot PLR(n) \cdot W_n}{T_w^{max} \cdot PLR_Z^{thr} \cdot p_Z} \quad (5)$$

$$W_n = \frac{\lambda_n}{\text{argmin}_i \lambda_i} \forall n, \forall i \in U \quad (6)$$

Step (1.b) sets each user pseudorandom-function (PRF). The algorithm tries to spread RBs allocation to each user among TTIs as much as possible and at the same time select the best channel for a user. The reason for the first criteria is that allocating different RBs in the same TTI for the same user does not utilize where $T_w(n)$ is the packet waiting time in a queue from the arriving instant to the scheduling instant, $PLR(n)$ is the packet loss rate of user which is the ratio between the transmitted and the dropped packets over the moving scheduling window M_w , $W(n)$ is the ratio of a user arrival rate to the minimum arrival rate, T_w^{max} is the maximum tolerated delay for the traffic type z , PLR_z^{thr} the maximum tolerated PLR for the traffic type z and P_z is the traffic priority. The RB allocation phase starts by initializing the RBs allocation matrix, $a_{n,r}$ the MCS assignment matrix, $b_{n,r}$ the set of RBs allocated to user n , S_r^n a TTI counter, t , the set of users, U and finally the priority function of each user, PRF the power resources efficiently since they must all have the same MCS (as required by C4). The second criteria stems from the fact that choosing an RB with the best channel condition is important for minimizing the transmit power. In the second stage, the algorithm allocates one RB to each user and guarantees that each TTI has only one RB allocated to a single user. In the third stage, RB allocations are done in proportional to user PRFs. First, a user is chosen according to its PRF. Then, a TTI that has the minimum number of RBs allocated to that user is chosen (Step (3.b)). An RB from the selected TTI with the best channel condition to that user is allocated to it (Step (3.c)). The algorithm concludes the allocation phase by updating the allocation matrix $a_{n,r}$ and the set of

RBs allocated to each user S_r^n

RB allocation phase

(1) Initialization

(a) Set $a_{n,r} = 0, b_{n,r} = 0, S_r^i = S_r, S_r^n = \emptyset, t = 1,$

$U = \{1, 2, \dots, N\};$

(b) Calculate PRF(n), when $n, i \in U;$

(2) For each $n \in U,$

(a) Find $r^* = \operatorname{argmax}_r h_{n,r}, \text{ when } r \in S_r^t \cap S_r^i;$

(b) Set $a_{n,r^*} = 1, S_r^i = S_r^i - r^*, S_r^n = S_r^n + r^*;$

(c) Add n to user subset $U_i = \{U_1, U_2, \dots, U_z\}$

(d) If $t > |S_r^t|,$ Set $t = 1,$ else Set $t = t + 1;$

(3) While $S_r^i \neq \emptyset,$

(a) Find $n^* = \operatorname{argmin}_n \frac{|S_r^n|}{PRF(n)};$

(b) Find

$t^* = \operatorname{argmin}_t |S_r^t \cap S_r^{n^*}|, \text{ when } t \in S_t, S_r^t \neq \emptyset;$

(c) Find $r^* = \operatorname{argmax}_r h_{n^*,r^*}, \text{ when } r \in S_r^{t^*} \cap S_r^i;$

(d) Set $a_{n^*,r^*} = 1, S_r^i = S_r^i - r^*, S_r^{n^*} = S_r^{n^*} + r^*;$

And we can complete this algorithm for MCS assignment phase starts with initializing the TTI counter, as fourth stage. And after this enter to fifth stage and gate from algorithm priority to the users' subsets according to their traffic type so it begins with the subset which represents the most delay sensitive traffic and ends with the subset which represents the least delay sensitive traffic.

And we can do fifth stage and the aims at assigning MCS for all RBs in a way to minimize the overall average packet delay and before this it can do priority to the users subsets according to their traffic type then it increases the MCS for those RBs in that TTI which yields the lowest average delay that mean RBs are already assigned the maximum MCS. If all users in a given TTI are excluded, then all RBs in this TTI are considered to have reached the maximum possible MCS and the TTI is excluded from any further processing and according to this it can do balances between reduction in weighted delay and power increase.

4. SIMULATION RESULTS

According to postulate Parameters we assume that each user supports MCSs according to BPSK, QPSK, 16-QAM, and 64-QAM. Arrival and service rates are in bits per frame and packet sizes are assumed to be fixed and of size 400 bits. Also we assume that the simulation environment has 10 users, and are divided into two equal groups; group A (with index $\{1, 2, \dots, 5\}$) and group B (with index $\{6, 7, \dots, 10\}$) where the arrival rates, λ_A of users in group A are equal to each other and allowed to vary whereas the arrival rates, λ_B of users in group B are always fixed and set to 150 bits per frame. The simulation results are demonstrating the performance of the proposed QoS algorithm and its comparison to the previous Resource Block Allocation algorithm [4]. Figure 3 demonstrates the overall average packet delay versus the arrival rates λ_A for both the QoS proposed algorithm and the previous RBA algorithm; it's found that the average packet delay of the QoS proposed algorithm is slightly larger than the delay of the RBA algorithm

especially when λ_A goes to large values as shown in figure (3) here there is no different in QoS requirement. We go to see user arrival in QoS algorithm with care for QoS requirements (application type, delay budget, loss rate) that mean if we serve Voice application with large arrival rate exhaust more resources to achieve their demands but for web we aspect less resources .which clearly in figure (4).

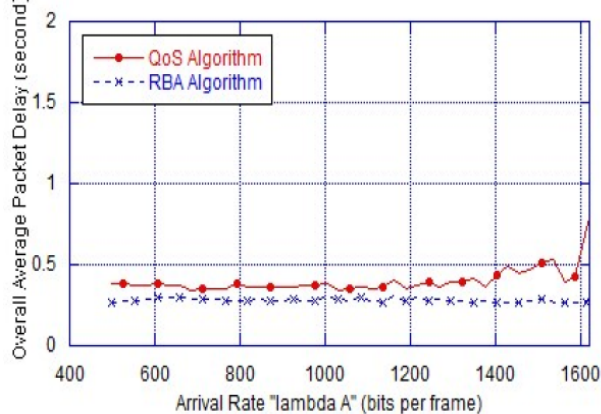

Figure 3. The average packet delay for the RBA and the proposed QoS Algo

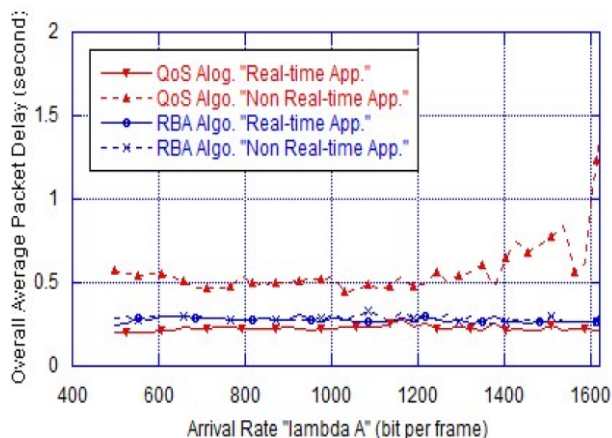

Figure 4. Differentiation between the real time application and the non-real time application in term of the average packet delay

5. CONCLUSION

This paper concentrate on problem in RBs and how to benefit from used minimum power in these resources allocation in better way in LTE system. It clearly for most advertisement paper concentrate power allocation and user separately therefore here it appear how to used cross-layering for MCS and RB algorithm as suggestion to solve problem. And from this paper it appear how perform MCS assignment for each RB to minimize packet delay

and it can observe that how to dealing with different users with allocation resources block according to CQIs .In the end applied the algorithm in simulation results for lower packet delay with rate arrival relative to non QoS previous for different user . Radio resource scheduling scheme based on softer frequency reuse is likely to offer the best performance compared to the other schemes discussed in this paper.

References

1. *Jim Zyren*, Overview of the 3GPP Long Term Evolution Physical Layer // free scale semiconductor, July 2007.
2. *L.M.C. Hoo, J. Tellado, and J.M. Cioffi*, Dual QoS Loading Algorithm for DMT Systems Offering CBR and VBR Services // IEEE Global Telecommunications Conference, 1998 vol. 1, pp. 25-30.
3. 3GPP Technical Specification, Evolved Universal Terrestrial Radio Access (E-UTRA); Medium Access Control (MAC) protocol specification // TS 36.321, June 2011 Version 10.2.0.
4. *H. Fattah, and H. Alnuweiri*, A Cross-Layer Design for Dynamic Resource Block Allocation in 3G Long Term Evolution System // In IEEE International Conference on Mobile Adhoc and Sensor Systems (MASS), 2009 pp. 929-934.
5. 3GPP Technical Specification, Evolved Universal Terrestrial Radio Access (EUTRA); Physical Channels and Modulation // March 2009 TS 36.211, V8.6.0.
6. *M. Voznak, M. Halas, B. Borowik and Z. Kocur*, Delay Model of RTP Flows in Accordance with M/D/1 and M/D/2 Kendall's Notation, INTERNATIONAL JOURNAL OF MATHEMATICS AND COMPUTERS IN SIMULATION // Issue 3, Volume 5, 2011
7. *Mohamed A. Abd El-Gawad, Mohsen M. Tantawy and Mohamed El-Mahallawy*, LTE QoS DYNAMIC RESOURCE BLOCK ALLOCATION WITH POWER SOURCE LIMITATION AND QUEUE STABILITY CONSTRAINTS // International Journal of Computer Networks & Communications (IJCNC) Vol.5, No.3, May 2013
8. *Tolga Girici, Chenxi Zhu, Jonathan R. Agre, and Anthony Ephremides*, Proportional Fair Scheduling Algorithm in OFDMA-Based Wireless Systems with QoS Constraints // JOURNAL OF COMMUNICATIONS AND NETWORKS, VOL. 12, NO. 1, FEBRUARY 2010.

Поступила в редакцию 29 октября 2013 г.

УДК 621.396.946.2

Аль-Шураифи Муштак Талиб¹, Резников Михайло¹, канд.техн.наук, **Аль-Заяди Хайдер Худхаир²**

¹Київський національний університет імені Тараса Шевченка, радіофізичний факультет, кафедра радіотехніки та радіоелектронних систем.

01601, Україна, м. Київ, вул. Володимирська, буд. 64/13,

E-mail: Mushtaq_talib2005@yahoo.com, e-mail: mir@univ.kiev.ua

²Національний університет "Львівська політехніка

Інститут телекомунікацій, радіоелектроніки та електронної техніки,

вул. Професорська 2, м.Львів, 79013, Україна, e-mail: hydertop@yahoo.com

Корекція хибних бітів, підвищення перепускної здатності та вплив на якість обслуговування і кодову схему модуляції ресурсного блоку для LTE шляхом управління ресурсами

У статті пропонується новий крос-шаровий алгоритм планування, який забезпечує кращі параметри QoS у програмах застосування, що діють у реальному масштабі часу. Запропонований алгоритм будує послідовність ресурсних блоків із різними схемами модуляції та кодування (MCS) відповідно до частоти появи хибних бітів (BER). У статті відмічається, що у теперішній час приділяється значна увага розробці алгоритмів управління ресурсами радіозв'язку. Такі алгоритми покращують використання радіоресурсів і одночасно надають користувачам систему телекомунікацій із підвищеною перепускною здатністю. Управління радіоресурсами передбачає управління потужністю передачі, управління мобільністю, планування ресурсів радіозв'язку тощо. Інтелектуальне управління ресурсами радіозв'язку є основним завданням LTE, виконання якого дозволить зробити LTE надійною технологією, здатною задовольнити потреби користувачів широкосмугових мобільних телекомунікацій у наступні роки. Цей алгоритм дозволить планувати доступні ресурси найкращим чином і надасть користувачам достатньо можливостей передачі даних, навіть за умови вільного пересування користувачів. Крім того, визначені ресурси QoS не конфліктуватимуть із вже призначеними ресурсами. Бібл. 8, рис. 4.

Ключові слова: універсальна наземна мережа радіодоступу з довготривалим удосконаленням (LTE), ресурсний блок (RB), якість обслуговування (QoS), кодова схема модуляції (MCS), управління ресурсами, інтервал часу передачі (TTI), індикатор якості каналу (CQI), базова станція (BS), блок фізичних ресурсів (PRB).

УДК 621.396.946.2

Аль-Шураифи Муштак Талиб¹, Резников Михаил¹, канд.техн.наук, **Аль-Заяди Хайдер Худхаир²**

¹Киевский национальный университет имени Тараса Шевченко, радиофизический факультет, кафедра радиотехники и радиоэлектронных систем,

ул. Владимирская, д. 64/13, г. Киев, 01601, Украина.

E-mail: Mushtaq_talib2005@yahoo.com , e-mail: mir@univ.kiev.ua .

²Национальный университет «Львовская политехника»,

Институт телекоммуникаций, радиоэлектроники и электронной техники,

Ул. Професорская, 2, г. Львов, 79013, Украина.

e-mail: hydertop@yahoo.com

Коррекция ложных битов, повышение пропускной способности и влияние на качество обслуживания и кодовую схему модуляции ресурсного блока для LTE путем управления ресурсами

В данной статье предлагается новый кросс-слойный алгоритм планирования, обеспечивающий лучшие параметры QoS в приложениях, работающих в реальном масштабе времени. Предложенный алгоритм выстраивает выделенные ресурсные блоки (RBs) с различными схемами модуляции и кодирования (MCS) в соответствии с частотой появления ошибочных битов (BER). В статье отмечается, что в настоящее время уделяется большое внимание разработке алгоритмов управления ресурсами радиосвязи. Такие алгоритмы улучшают использование радиоресурсов, предоставляя пользователям систему телекоммуникаций с повышенной пропускной способностью. Управление радиоресурсами включает в себя управление мощностью передачи, управление мобильностью, планирование ресурсов радиосвязи и др. Интеллектуальное управление ресурсами радиосвязи является основной задачей LTE, которая призвана сделать LTE надежной технологией, удовлетворяющей потребности пользователей широкополосных мобильных телекоммуникаций в предстоящие годы. Этот алгоритм позволит планировать доступные ресурсы наилучшим образом и предоставит пользователям достаточно возможностей передачи данных, даже когда они свободно передвигаются. Кроме того, назначенные ресурсы QoS не будут интерферировать с уже назначенными ресурсами. Библ. 8, рис. 4.

Ключевые слова: универсальная наземная сеть радиодоступа с долгосрочным усовершенствованием (LTE), ресурсный блок (RB), качество обслуживания (QoS), кодовая схема модуляции (MCS), управление ресурсами, интервал времени передачи (TTI), индикатор качества канала (CQI), базовая станция (BS), блок физических ресурсов (PRB).

Список использованных источников

1. Jim Zyren, "Overview of the 3GPP Long Term Evolution Physical Layer", free scale semiconductor, July 2007.
2. L.M.C. Hoo, J. Tellado, and J.M. Cioffi, (1998) "Dual QoS Loading Algorithm for DMT Systems Offering CBR and VBR Services", IEEE Global Telecommunications Conference, vol. 1, pp. 25-30.
3. 3GPP Technical Specification, (June 2011) "Evolved Universal Terrestrial Radio Access (E-UTRA); Medium Access Control (MAC) protocol specification", TS 36.321, Version 10.2.0.
4. H. Fattah, and H. Alnuweiri, (2009) "A Cross-Layer Design for Dynamic Resource Block Allocation in 3G Long Term Evolution System", In IEEE International Conference on Mobile Adhoc and Sensor Systems (MASS), pp. 929-934.
5. 3GPP Technical Specification, (March 2009) "Evolved Universal Terrestrial Radio Access (EUTRA); Physical Channels and Modulation", TS 36.211, V8.6.0.
6. M. Voznak, M. Halas, B. Borowik and Z. Kocur, "Delay Model of RTP Flows in Accordance with M/D/1 and M/D/2 Kendall's Notation", INTERNATIONAL JOURNAL OF MATHEMATICS AND COMPUTERS IN SIMULATION, Issue 3, Volume 5, 2011
7. Mohamed A. Abd El-Gawad, Mohsen M. Tantawy and Mohamed El-Mahallawy, "LTE QOS DYNAMIC RESOURCE BLOCK ALLOCATION WITH POWER SOURCE LIMITATION AND QUEUE STABILITY CONSTRAINTS", International Journal of Computer Networks & Communications (IJCNC) Vol.5, No.3, May 2013
8. Tolga Girici, Chenxi Zhu, Jonathan R. Agre, and Anthony Ephremides, "Proportional Fair Scheduling Algorithm in OFDMA-Based Wireless Systems with QoS Constraints", JOURNAL OF COMMUNICATIONS AND NETWORKS, VOL. 12, NO. 1, FEBRUARY 2010